

S/SS/SC

Quick Disconnect with Spring or Spring Clip

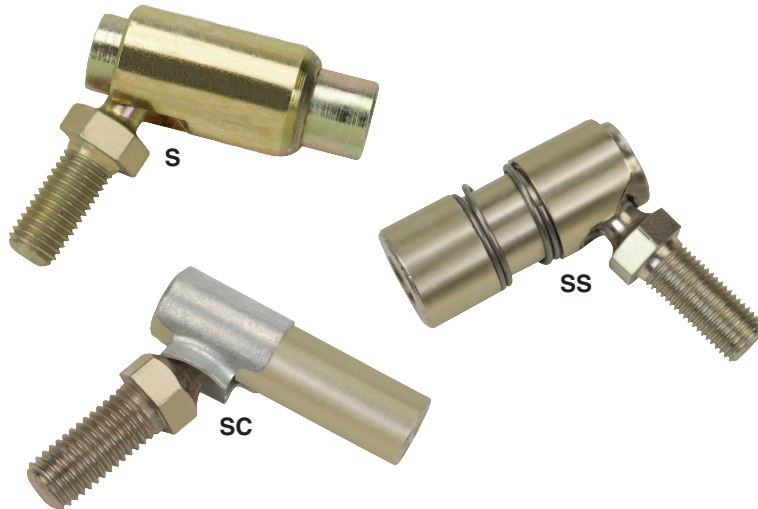

Ball Joints

Suitable for applications requiring quick disconnect capabilities, the Cablecraft S/SS/SC Series offers three different styles of fast assembly/disassembly ball joints.

- S Series: spring loaded sleeve, smaller ball joint sizes
- SS Series: exposed spring loaded sleeve, larger sized applications
- SC Series: ball stud is retained by a spring clip, for lower load and fewer disconnection requirements, most economical alternative

S/SS/SC Series "quick disconnect" ball joints are especially effective in applications requiring numerous and/or fast assembly/disassembly of the ball joint. Ball stud, sleeve and body components are produced from low carbon steel and are zinc plated and yellow dichromate treated for extended corrosion resistance. The ball stud is heat treated on all models for extended wear resistance. Right and left-handed thread versions available.

The S/SS/SC Series are just three of many within our broad line of ball joints. For full product line detail, contact us for a comprehensive catalog or visit www.cablecraft.com and download individual product data sheets and other product information.



Description:

S/SS/SC Series Ball Joints
Quick Disconnect with Spring
or Spring Clip

Applications:

Light to medium-duty linkage applications, including:

- Cable assemblies
- Light industrial applications
- Agricultural, lawn and garden equipment
- Racing (throttle links)

Features:

- Three different configurations, all with steel ball stud, sleeve and body to match your load and cost requirements
- Quick pull back, "no tools required" disconnect assembly provides easier access, faster maintenance
- Can be used in a wide range of temperatures: -60°F — 250°F (-51°C — 121°C)
- Right and left-handed versions available
- Custom sizes and assemblies can be built to your specifications
- S/SS Series meets SAE J490 specification (S: type S/style 1 SS: type S/style 2)

Other Related Products:

- SR-G Hardened Steel Housing, Retaining Ring with Rubber Grommet
- R-G Steel Housing, Staked Design with Rubber Grommet

S/SS/SC

Material

Ball Stud

- Low Carbon Steel, Heat Treated
- Zinc Plated, Yellow Dichromate Treated

Sleeve

- Low Carbon Steel
- Zinc Plated, Yellow Dichromate Treated

Body: S and SS

- Low Carbon Steel

Body: SC

- Low Carbon Steel, Heat Treated
- Zinc Plated, Yellow Dichromate Treated

Spring: S and SS

- Stainless Steel

Spring Clip: SC

- Hardened Spring Steel

Linking Motion & Control...

The Cablecraft Solution

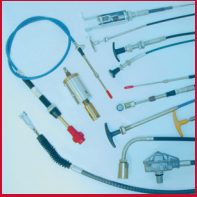

Quick Disconnect
with Spring or Spring Clip

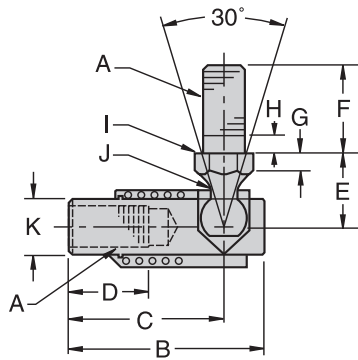

Type S

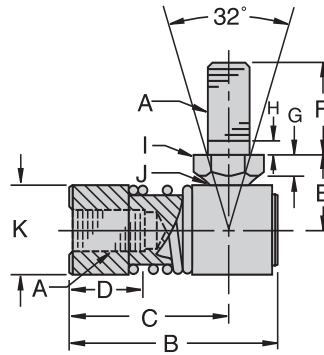

Type SS

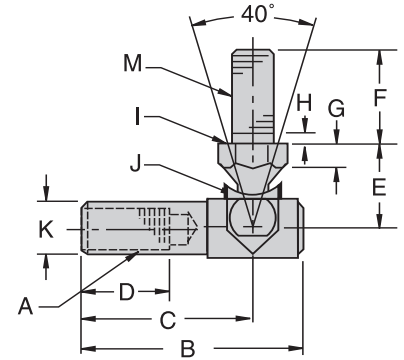

Type SC

S/SS/SC CHART

Part Number	A UNF	B ±.020	C ±.020	D MIN	E ±.020	F ±.020	G REF	H REF	I REF	J REF	K REF	M UNF	Ball Diameter REF
S103	10-32	1.094	.906	.437	.437	.437	.125	.062	.312	.171	.312	—	.253
S107S	1/4-28	1.094	.906	.531	.469	.562	.141	.062	.312	.171	.312	—	.253
SS1002	1/4-28	1.250	.969	.531	.469	.562	.125	.078	.375	.192	.562	—	.345
SS1003	5/16-24	1.453	1.125	.594	.531	.687	.125	.094	.437	.224	.625	—	.403
SS1004	3/8-24	1.750	1.375	.812	.687	.875	.156	.109	.500	.273	.750	—	.491
SC103	10-32	1.156	.875	.484	.437	.437	.187	.078	.312	.135	.312	10-32	.250
SCS103	10-32	1.156	.875	.484	.437	.562	.125	.078	.312	.135	.312	1/4-28	.250
SC107	1/4-28	1.250	.969	.531	.437	.562	.125	.078	.312	.135	.312	1/4-28	.250
SCS107	1/4-28	1.250	.969	.531	.437	.437	.125	.078	.312	.135	.312	10-32	.250

WARNING!

Since the manufacturer is unable to determine all applications in which a part may be placed, it is the user's responsibility to determine the suitability of the part for its intended use. This is especially true where safety is a factor. Incorrect application or installation may result in property damage, bodily injury, or death. For technical assistance, call 260-749-5105.

Cablecraft®
Cablecraft Motion Controls

2110 Summit Street
New Haven, Indiana USA 46774
Tel 260 749-5105 Fax 260 749-5677

4401 South Orchard Street
Tacoma, Washington 98411 USA
Tel 253 475-1080 Fax 253 474-1623

Diplocks Way-South Road
Hailsham, East Sussex BN27 3JF, England
Tel 44 1323 841510 Fax 44 1323 845848

www.cablecraft.com